



EPiC Series in Computing

Volume 81, 2022, Pages 132–140

Proceedings of 11th International Congress
on Advanced Applied Informatics



Airborne Navigation by Geomagnetic Field Based on LSTM

Xin Peng¹, Yibo Wei¹, and Weibao Zou¹

¹Chang'an University, Xi'an, China

2290320625@qq.com, weiyb1997@163.com, hkzouwb@yahoo.com

Abstract

To solve the problem of low navigation accuracy of traditional geomagnetic matching navigation algorithm, a geomagnetic navigation and positioning algorithm based on long-term and short-term memory neural network (LSTM) is proposed in this paper. In this algorithm, the corresponding geodetic coordinates are derived from geomagnetic measurements based on least-square linear fitting. Therefore, the geomagnetic matching is implemented. Then the position of the aircraft at the next time is predicted by the LSTM algorithm. Furthermore, the corresponding geodetic coordinates derived from the geomagnetic sensor are modified to complete the geomagnetic navigation and positioning. In this paper, the geomagnetic field data of a certain region are obtained by IGRF-13. The multi-time simulated flight trajectory is used for simulation experiments. The results show that the proposed methods are reliable to transform the geomagnetic measurements to geodetic coordinates. Also, the artificial intelligent method is to make up for the measurement error of the geomagnetic sensor and improve the accuracy of the geomagnetic navigation.

1 Introduction

Geomagnetic navigation is an all-time, all-weather, all-region passive autonomous navigation technology, which has the characteristics of strong autonomy and error does not accumulate with time. The pre-storage of a prior geomagnetic database in the navigation carrier is a prerequisite for geomagnetic navigation. According to the different data sources, the prior geomagnetic database can be divided into two forms: the measured database based on the measured geomagnetic data and the model database constructed by the geomagnetic model. However, without considering the limitations of geomagnetic survey technology, both the measured database and the model database also have the problem of storing too much data in the actual navigation application, so that they cannot be carried on the navigation carrier. This is because the two databases store geodetic coordinates and corresponding geomagnetic element information at certain intervals in the navigation area, so they cannot store prior geomagnetic data on a large scale. To solve the problem that the storage of the

existing geomagnetic database is too large to meet the requirements of practical navigation and positioning applications, a new database establishment method and its corresponding fast retrieval and positioning method are adopted in this paper. The database stores the fitting model of geomagnetic field elements by linear least square fitting based on geodetic coordinates, and its corresponding retrieval method is to obtain estimated geodetic coordinates by solving fitting model equations, and then determine that the estimated geodetic coordinates obtained from the fitting equations used by the next level subgraph to the end of the minimum subgraph are the final matching geodetic coordinates.

With the development of artificial intelligence, the method of deep learning arises at the historic moment, and the method of deep learning has gradually become the mainstream at present. Deep learning theory can solve the problem of the disaster of dimensionality through distributed computing. Compared with the traditional shallow learning structure, a deep neural network can model deep and complex nonlinear relationships by using distributed and hierarchical feature representation [1]. And deep learning technology has been well developed and widely used to extract information from a variety of data, and it has achieved great success in the fields of computer vision, speech recognition, and natural language processing. At the same time, short-term forecasting based on the deep learning method is also used in various industries, such as stock forecasting, air pollution forecasting, traffic forecasting, and other fields. Under the guidance of deep learning theory, many variants of neural networks have been proposed to assist time-series data prediction. Typical examples include feedforward neural network [2], RBF neural network [3], spectrum-based neural network [4], and recurrent neural network (RNN) [5]. Among them, RNN is widely regarded as a suitable method to capture the spatiotemporal evolution of traffic flow. RNN occupies a dominant position in the research field that contains sequential data (such as text, audio, and video). However, previous studies have proved that the traditional stochastic neural network cannot well capture the long-term evolution process, and because of the disappearance of gradient and the existence of explosion gradient, it is difficult to train a neural network with a minimum lag of 5-10. To solve this problem, the long-term and short-term memory (LSTM) [6] network is applied to the flight trajectory prediction of aircraft. Compared with traditional RNN, the LSTM network considers the spatiotemporal correlation of aircraft flight trajectory systems through a two-dimensional network composed of multiple memory units and can capture the characteristics of time series in a long time [7]. Therefore, better performance can be achieved by using the LSTM network for trajectory prediction.

2 Geomagnetic Positioning Method

2.1 Least Square Fitting Method of Geomagnetic Elements

The earth's magnetic field is a vector field, which can be divided into five directional component elements and two angular component elements. the five directional elements are northward component X, eastward component Y, vertical component Z, horizontal component H, and total magnetic field intensity F. the magnetic field intensity of each directional component can be made into a digital geomagnetic map. The intensity value of the magnetic field component in a certain direction at a point (Lon_1, Lat_1) in the local area of geodetic coordinates can be expressed as a function $x_f(Lon_1, Lat_1)$ on the digital geomagnetic map, where x_f is the geomagnetic direction element, Lon_1 is the geodetic longitude of the point, and Lat_1 is the geodetic latitude of the point. In this way, the longitude, latitude, and the corresponding geomagnetic field direction elements are selected as the coordinate axis to draw the three-dimensional geomagnetic field element surface map of the local area.

Through the simulation, it is found that the intensity of the main magnetic field in the five directions around the world changes slowly, so the plane fitting can be carried out in the local region,

that is, a linear function is used to approximately fit the nonlinear function x_f (Lon, Lat). At present, there are many mature fitting methods, comprehensively considering the accuracy and operation speed and other indicators, this paper finally decided to adopt the more mature linear least square fitting method. The specific methods are as follows: two elements of geomagnetic field direction are selected, linear least square fitting is carried out, and the fitting model of binary first-order geomagnetic elements is established.

$$\begin{cases} x_1 = a_1 * Lat + b_1 * Lon + c_1 + \varepsilon_1 \\ x_2 = a_2 * Lat + b_2 * Lon + c_2 + \varepsilon_2 \end{cases} \quad (1)$$

In the formula, the dependent variables x_1 and x_2 are two different geomagnetic field direction elements; Lon refers to the geodetic longitude of the location point, Lat is the geodetic latitude of the location point; a and b are coefficients, c is a constant term, and ε is measurement noise.

According to the principle of least squares, using all the sampled geomagnetic field intensity elements in the fitting area and the corresponding geodetic latitude and longitude data, the optimal solution of the coefficient vectors a, b, and c of the fitting model is calculated so that the variance $\sum_{i=1}^m \varepsilon_i^2$ is the smallest, and Obtain the best estimates of the coefficients of the fitted model $\hat{a}_1, \hat{a}_2, \hat{b}_1, \hat{b}_2, \hat{c}_1$ and \hat{c}_2 to determine the best fitting model in the fitting area.

2.2 Geomagnetic Navigation and Positioning Method Based on Hierarchical Submap

To improve the accuracy of navigation and positioning, the effects of fitting area and fitting data on the accuracy of least square fitting are studied in this paper. After many simulation experiments, it is found that the amount of fitting data has little influence on the fitting accuracy, but the fitting area has a great influence on the fitting accuracy of this method, that is, the larger the fitting area, the worse the fitting accuracy. However, if the total fitting area is too small, it will reduce the value of the research, so the focus of this paper is how to improve the fitting accuracy without reducing the total fitting area.

To meet the requirements of large-area navigation and accuracy at the same time, the following methods can be adopted: a large rectangular area is selected as the navigation area in the geodetic coordinate system, and two different geomagnetic elements are selected for the least square geomagnetic element fitting. the location accuracy of the observation point is evaluated and the range of the next layer fitting area is calculated to obtain a new fitting area. And this new fitting region will be smaller than the fitting area of the previous layer. And each new fitting area is refitted by least-square geomagnetic elements, and the fitting accuracy will be improved due to the decrease of fitting area. The range of the fitting area of the next layer is evaluated again, and the fitting area with a smaller fitting area and higher fitting accuracy are obtained. Perform the above steps repeatedly until the area of the final fitting area reaches the requirement of fitting accuracy.

In the specific application, to make this method not only have high accuracy but also have the characteristics of fast positioning, in the geodetic coordinate system, a rectangular navigation area (called general map) can be divided into several overlapping rectangular regions (called first-order sub-maps), and each first-level submap area is again divided into several overlapping rectangular regions (called secondary sub-maps). In turn, it is divided into N-level subgraphs that meet the accuracy requirements [8]. To make the method have the characteristic of fast positioning, N should not be too large. The sub-map regions of all levels overlap each other to avoid the observation points using the wrong corresponding model at the boundary, which can improve the positioning accuracy. As shown in Figure 1, a fitting area is divided into two rows and two columns with a total of four sub-graph areas.

The number of hierarchical layers N can be determined by the area of each level of submap and the fitting accuracy of the Nth level of submap. The size of each level of a submap area needs to be

determined according to the change characteristics of the two selected geomagnetic elements at different positions, but because This feature changes smoothly in a small area. In this paper, the average division method is selected for the convenience of research.

Then, sample the data of the divided regions and the sub-maps at various levels at a certain sampling interval. The higher the level, the smaller the sampling interval, and then the least-squares geomagnetic field element fitting is performed, and the fitting model information (a, b, c) of the general map and all levels of sub-maps are stored, as well as the geodetic longitude and latitude coordinates of the lower-left corner and upper right corner of the general map and all levels of sub-maps. The specific steps are as follows:

1. The accuracy of the geomagnetic survey points is evaluated in the general navigation map, that is, the binary first-order equations are solved, and the estimated latitude and longitude corresponding to the geomagnetic survey points are obtained. The point pointed to by the estimated longitude and latitude is the estimated geomagnetic survey point.
2. According to the estimated geodetic longitude and latitude, determine the first-order subgraph with the nearest center point, then use the fitting model of the first-order subgraph to solve the estimated geodetic longitude and latitude again, and then use the estimated geodetic longitude and latitude to determine the fitting model of the next subgraph. Repeated until the end of the solution of the N-level subgraph model, the final estimated geodetic longitude and latitude is the geodetic coordinate with the least error.

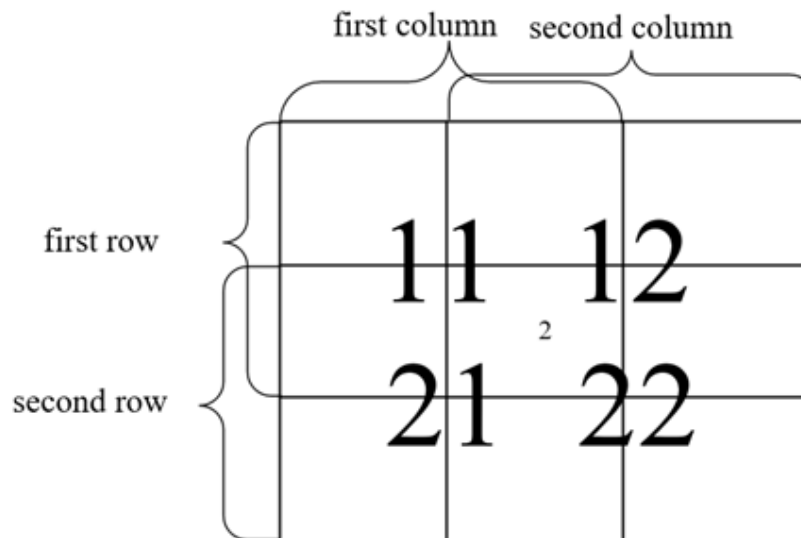

Figure 1: Divides a fitting region into four sub-graph regions

3 LSTM Trajectory Prediction and Positioning Method

3.1 LSTM Neural Network Structure

Long-term and short-term memory network (LSTM) is a special Recurrent Neural Network (RNN). LSTM replaces the hidden layer unit of traditional RNN with a set of interrelated recursive sub-networks, namely memory module. The memory module contains one or more memory cells, and

modifies the cell state at the current moment, and determines the output content through the forget gate, the input gate, and the output gate. In the flight trajectory prediction network in this paper, the input gate, output gate, and forgetting gate correspond to the writing, reading and previous state reset operation of the flight trajectory characteristic data sequence, respectively.

Figure 2 shows the LSTM structure containing one memory cell. It can be seen from Figure 2 that in the memory cell of the LSTM network, the input is the h_{t-1} output by the cell at the previous moment, and all the cell states at the previous moment $\{c_{t-1}^1, c_{t-1}^2, c_{t-1}^3, \dots, c_{t-1}^n\}$ and the input x_t at the current time, the output is the cell output h_t at the current time t , and all the cell states at the current time $\{c_t^1, c_t^2, c_t^3, \dots, c_t^n\}$; In the learning process of the neural network, the cell adds new information through the input gate, and deletes unimportant information through the forget gate, thereby ensuring the memory function of LSTM.

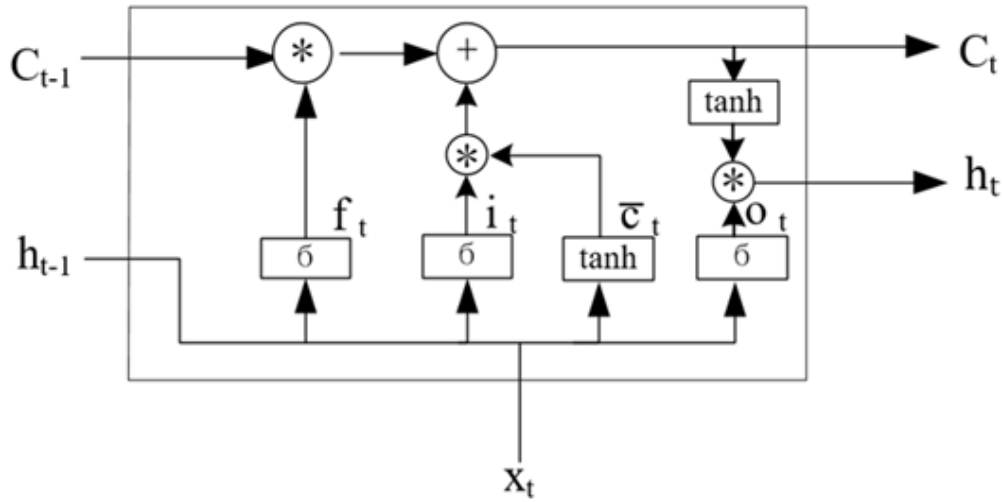

Figure 2: LSTM structure

3.2 Design of LSTM Flight Trajectory Prediction Model

In the geomagnetic navigation of the aircraft, the aircraft will be affected by wind and gravity in the course of a flight, and the flight trajectory shows certain nonlinear characteristics, so it is difficult to predict the trajectory of the aircraft accurately by the way of linear fitting, but the LSTM trajectory prediction model has excellent nonlinear fitting conditions as a neural network model with excellent performance in processing time-series data. It has a strong ability to capture the timing-dependent characteristics of samples, which ensures that it can be predicted through multiple historical time trajectory information and then ensure the prediction accuracy.

The flight trajectory prediction model in this paper predicts the position of the aircraft at the current moment based on the flight trajectory characteristics of n historical moments. The flight trajectory feature expression of the current time is shown in formula (2), and the output feature is shown in formula (3):

$$X(t) = \{\text{lat}, \text{lon}, v, a, c\} \quad (2)$$

$$H(t) = \{\text{lat}, \text{lon}\} \quad (3)$$

Among them, lat, lon represents the latitude and longitude of the geodetic coordinates of the aircraft at the current time, v and a are the speed and acceleration of the aircraft at the current time, respectively, and c is the flight direction of the aircraft at the current time.

To realize the flight trajectory prediction of the aircraft, the flight trajectory characteristics $X(t-n+1)$, $X(t-n)$, $X(t-n-1)$, ..., $X(t-1)$ for n consecutive moments are used as the input of the prediction network to predict the aircraft position $H(t)$ at the next time, that is, the expression of the flight trajectory prediction is shown in the formula (4).

$$H(t) = \{X(t-n+1), X(t-n), X(t-n-1), \dots, X(t-1)\} \quad (4)$$

Because there are many attributes in the LSTM input $X(t)$, and their ranges and units are also different, this situation will affect the results of data analysis. To eliminate the influence between different attribute features, it is necessary to carry out data standardization processing to solve the comparability between data attributes. After the original data is standardized, each attribute is in the same order of magnitude, which is suitable for comprehensive comparative evaluation. And because of the small difference between the geodetic coordinate attribute values of the output and input in this paper, the deviation standardization method is used to normalize the input features to ensure that the range of all input features is between $[0,1]$. The increase of the number of nodes in the hidden layer will lead to an increase in time cost, too many nodes in the hidden layer will damage the generalization ability of the network, and too few nodes cannot effectively learn the time series characteristics, resulting in low prediction accuracy. Based on the fact that flight trajectory prediction requires high prediction accuracy, single-layer LSTM is used to realize trajectory prediction.

4 Simulation Experiment

4.1 Simulation Experiment of Geomagnetic Positioning

Perform simulation experiments on the rectangular latitude and longitude range of $107.88938^\circ \sim 109.99875^\circ\text{E}$ and $33.29757^\circ \sim 35.18721^\circ\text{N}$ on the geodetic coordinate system, and locate a point in this range through two different geomagnetic field elements, using the international geomagnetic reference updated in 2020 The field model IGRF-13 [9] simulates the real magnetic field in this area, and obtains the magnetic field intensity maps in five directions. The minimum resolution of the geomagnetic map is one ten-thousandth of a degree in latitude and longitude.

Because the positioning accuracy is related to the area of the final submap, according to the minimum area accuracy of the least square fitting, the total magnetic field intensity F and the eastward component Y are selected as the fitting geomagnetic elements. Considering the need for rapid positioning, two-level subgraphs are divided based on the navigation general map. To verify the efficiency of this method, the general map is divided into 16 first-level subgraphs, and each first-level subgraph is again divided into 16 second-level subgraphs. The area of each level subgraph is $4/25$ of the area of the previous level subgraph, and the adjacent subgraphs at the same level overlap each other by $1/2$. 39191 geomagnetic survey points were obtained in the navigation master map with a sampling interval of 0.01° , and 151981 geomagnetic survey points were obtained with a sampling interval of 0.002° in all the first-order sub-maps, and 97393 geomagnetic survey points were obtained with a sampling interval of 0.001° in the second-order submap.

The simulation results are shown in Table 1. The data of 39191 geomagnetic survey points sampled from the general navigation map are analyzed by using the geomagnetic positioning method in this paper. Finally, the average absolute error of longitude is 0.000369° and the root mean square error is 0.000396° . The average absolute error of latitude is 0.000180° , the root mean square error is 0.000192° , and the maximum absolute errors of longitude and latitude are 0.002013° and 0.000785° , respectively. This is due to the large fitting error at the edge of the navigation map, the estimated longitude and latitude may not be in the navigation area, resulting in the final corresponding second-level sub-image cannot be better positioning. The minimum absolute errors of longitude and latitude are about $7 \times 10^{-8}^\circ$.

Serial number	True value of lat and lon/ $^{\circ}$	Estimation lat and lon/ $^{\circ}$	Absolute value of lat and lon error/ $^{\circ}$	Errors in length /m
1	121.80897	121.808665	0.000305	43
	30.14872	30.148443	0.000277	
2	121.90897	121.909339	0.000369	42
	28.98872	28.988867	0.000147	
3	122.64938	122.649502	0.000123	14
	29.94656	29.946622	0.000062	
4	121.85897	121.858635	0.000334	36
	29.39872	29.398580	0.000139	
5	122.54897	122.549444	0.000474	52
	29.49872	29.498951	0.000231	

Table 1: Partial simulation positioning results without noise

If the geodetic longitude and latitude error of each sampling point is converted into the spherical distance, the average absolute error of positioning is 43 meters, of which the maximum error is 215 meters and the minimum error is close to 0 meters.

As shown in Table 2, when the geomagnetic positioning method is within $\pm 0.1\text{nT}$, $\pm 0.5\text{nT}$, $\pm 1\text{nT}$, and $\pm 5\text{nT}$, the longitude and latitude errors in the general navigation map area gradually increase, and the corresponding multiple relations are re-established. In addition, it is consistent with the error characteristics of the second-level sub-area of the navigation center. It shows that the method is universal in all positions in the general navigation map.

	General map area			Secondary map area		
	Longitude RMSE/ $^{\circ}$	Latitude RMSE/ $^{\circ}$	Mean spherical error / $^{\circ}$	Longitude RMSE/ $^{\circ}$	Latitude RMSE/ $^{\circ}$	Mean spherical error / $^{\circ}$
0nT	0.000396	0.000192	0.000412	0.000388	0.000187	0.000412
$\pm 0.1\text{nT}$	0.000767	0.000332	0.000711	0.000756	0.000326	0.000702
$\pm 0.5\text{nT}$	0.003304	0.001362	0.003233	0.003253	0.001341	0.003188
$\pm 1\text{nT}$	0.006575	0.002698	0.006444	0.006497	0.002667	0.006386
$\pm 5\text{nT}$	0.032718	0.013503	0.032126	0.032330	0.013289	0.031783

Table 2: Experimental results based on simulation method

4.2 Simulation Experiment of LSTM Flight Trajectory Prediction

This part of the simulation experiment uses 3.1 methods to convert the geomagnetic information obtained by the geomagnetic sensor on the aircraft into geodetic coordinate information and then uses the geodetic coordinate information obtained from the positioning of the first n times to predict the geodetic coordinates of the positioning next time.

In this simulation experiment, the flight trajectory data of 5002 times are obtained as data sets in the simulation area of part 3.1, in which the ratio of the training set to test set is 4:1. In this part of the experiment, the Keras training framework is used, the mean square error (MSE) function is used as the loss function of neural network training, and the training optimizer is Adam. The epoch is set to

50, the batch size is set to 64, the learning rate is set to 10^{-6} , and the memory step is set to 10. The longitude and latitude fitting results of the test set are shown in Figure 3. Through the quantitative analysis of the prediction results, the prediction accuracy of the prediction network can be obtained, and the final accuracy is expressed by root mean square error (RMSE), as shown in Table 3.

The experimental results show that the predicted track is consistent with the real track, and the prediction accuracy is better.

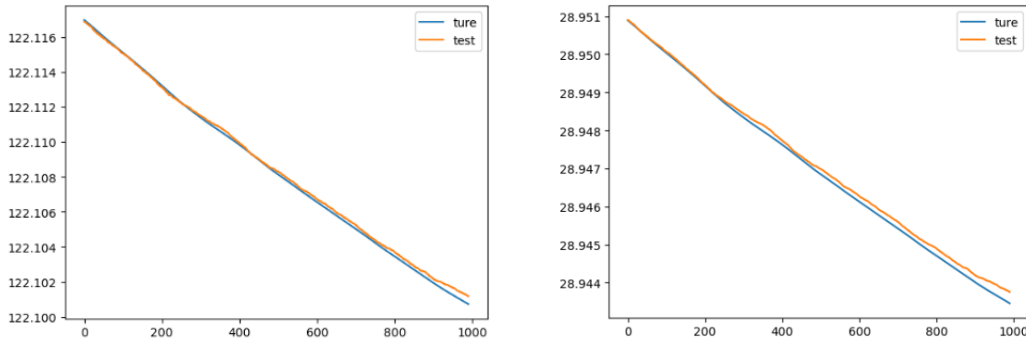

Figure 3: Longitude (left) and latitude (right) of the flight trajectory prediction-fitting diagram

	LON($^{\circ}$)	LAT($^{\circ}$)
RMSE	1.40×10^{-4}	1.86×10^{-4}

Table 3: Flight trajectory prediction accuracy

5 Conclusion

In this paper, a geomagnetic navigation and positioning algorithm based on long-and short-term memory neural networks is proposed. The geomagnetic database is constructed based on the least square fitting method. The database can convert the geomagnetic information of the position into geodetic coordinate information and complete the geomagnetic positioning. The average absolute error of the positioning longitude is 0.000369° . The average absolute error of latitude is 0.000180° , which completes the transformation of geographic information. Furthermore, the geodetic coordinate information of the next moment is predicted by the geodetic coordinate information, velocity, acceleration, and flight direction of the aircraft in the first 10 moments, and the prediction accuracy is also better (Table 3).

Acknowledgment

This work was supported by the Project of National Defense Science and Technology Innovation of China (No. 19-163-00-KX-002-030-01).

References

- [1] W. Huang, G. Song, H. Hong, and K. Xie, "Deep architecture for traffic flow prediction: deep

- belief networks with multitask learning,” *IEEE Transactions on Intelligent Transportation Systems*, vol. 15, no. 5, pp. 2191-2201, 2014.
- [2] D. Park and L. R. Rilett, “Forecasting freeway link travel times with a multilayer feedforward neural network,” *Computer-Aided Civil and Infrastructure Engineering*, vol. 14, no. 5, pp. 357-367, 1999.
- [3] B. Park, C. J. Messer, and T. Urbanik, “Short-term freeway traffic volume forecasting using radial basis function neural network,” *Transportation Research Record*, vol. 1651, no. 1, pp. 39-47, 1998.
- [4] D. Park, L. R. Rilett, and G. Han, “Spectral basis neural networks for real-time travel time forecasting,” *Journal of Transportation Engineering*, vol. 125, no. 6, pp. 515-523, 1999.
- [5] P. Lingras, S. Sharma, and M. Zhong, “Prediction of recreational travel using genetically designed regression and time-delay neural network models,” *Transportation Research Record*, vol. 1805, no. 1, pp. 16-24, 2002.
- [6] S. Hochreiter and J. Schmidhuber, “Long short-term memory,” *Neural computation*, vol. 9, no. 8, pp. 1735-1780, 1997.
- [7] Z. Zhao, W. Chen, X. Wu, P. C. Chen, and J. Liu, “LSTM network: a deep learning approach for short-term traffic forecast,” *IET Intelligent Transport Systems*, vol. 11, no. 2, pp. 68-75, 2017.
- [8] Y. Q. Niu and B. Zheng, “A new randomized Gauss–Seidel method for solving linear least-squares problems,” *Applied Mathematics Letters*, vol. 116, 107057, 2021.
- [9] I. Wardinski, D. Saturnino, H. Amit, A. Chambodut, B. Langlais, M. Manda, and E. Thebault, “Geomagnetic core field models and secular variation forecasts for the 13th International Geomagnetic Reference Field (IGRF-13),” *Earth, Planets and Space*, vol. 72, no. 1, pp. 1-22, 2020.