



Design and Fabrication of Automatic Dustless Chalk Making Machine

Hardik Chavan, Pratik Ghodke, Satish Hatkar and Nilesh Nagare

EasyChair preprints are intended for rapid dissemination of research results and are integrated with the rest of EasyChair.

January 29, 2020

“DESIGN AND FABRICATION OF AUTOMATIC DUSTLESS CHALK MAKING MACHINE”

Hardik Chavan¹, Pratik Ghodke², Satish Hatkar³, Nilesh Nagare⁴

¹Department of Mechanical Engineering, Mumbai University, Mumbai
Email: hardikchavan707@gmail.com

²Department of Mechanical Engineering, Mumbai University, Mumbai
Email: pratioghodke@gmail.com

³Department of Mechanical Engineering, Mumbai University, Mumbai
Email: satishhatkar888@gmail.com

⁴Department of Mechanical Engineering, Mumbai University, Mumbai
Email: nileshnagare@viva-technology.org

Abstract— *In today’s world of automation the traditional chalk making machine is left behind due to lack of automation in this industry. Our project work includes the design and fabrication of automatic dustless chalk making machine. Our main aim is to automate the traditional chalk making machine for ease of manufacturing. The machine consists of traditional machine components such as Hopper, Mould and Ejectors as well as electronic system for the purpose of automation.*

The basic working of this machine is to mix the ingredients of chalk in the Hopper with the help of AC motor, this mixture is poured in the mould and dried with the help of heating system. The ejection system ejects the chinks from the mould, the ejected chinks are collected in a tray. All the above processes are automated with the help of Electronic Control Unit (ECU). The automation system consists of speed controller of AC motor, sweeping movement is controlled by servo motor, the sliding movement of the mould and ejection movement is control by stepper motors. The sensors like temperature and humidity, displacement are used to sense various parameters.

Keywords—*Automatic, Chalk, Design, Dustless, Fabrication, Engineering*

I. INTRODUCTION

In our project we are designing and fabricating the automatic dustless chalk making machine. Our main purpose of the project is to reduce the manpower and production time. In order to achieve this we have used electronic control unit such as Arduino-Mega for the automation in the traditional chalk making machine and implementing of direct heating of the mold in order to reduce the drying time thus making the process faster .

The ECU controls the various motor viz. stepper motor and servo motor, it also alters its parameters like speed and movements. We use induction heating to heat the water and this heated water is circulated through the mold surface for better heating. For easy ejection of the chalk from the mold the ejectors are used to penetrate through the mold holes pushing the chinks downward in the tray placed below.

The chalk composition used is same as the dustless chalk available in the market. The machine will produce 225 chalk at one pass, we can also produce different colour chinks as per requirement.

II. PROBLEM DEFINITION

2.1 Problem statement

After searching for various prototypes of chalk making machines, we found out that the low scale machines are not automatic and loaded manually. The processes take several hours for completion of one batch of chalks. The available automatic machines required skilled labour, more area for installation and their initial cost is high as compared to low scale machines.

The low scale chalk making industry uses old school chalk making machines which are incapable of mass production. The machine used require more efforts and man hours which in leads to high labour cost and eventually reduces the profit. The chalk produce from this type of machine takes more time for drying. Due to more idle time the quality of the chalk manufactured is poor.

2.2 Objective

The main objective of the project is to design and fabricate Automatic Dustless Chalk making machine to reduce the manpower, process time, increase the production and quality of chalk and better utilization of traditional chalk making machine.

2.3 Advancements

Following modifications will be made in our machines to overcome the drawbacks of old school machines-

1. In our machine we are using ECU control for automation of machine, which will control the various operation of the machine.
2. For the purpose of reducing the process time of drying we are implementing integrated heating of mould.
3. Our machine can produce 225 numbers of chalk per batch in approx. 2hrs, which eventually reduces production lead time and hence increase in productivity.
4. As the chalk business is quantity type more production of chalks, ultimately increases the profit of manufacturer.
5. As the machine is fully automated the quality of product will be as per desired standard.
6. The efficiency of this machine will be higher than traditional chalk machines.

As the processes are automatic stepper motor are used to move the mould from one section to another and actuation of ejector is also carried out by the stepper motor of high capacity. To control the stepper motors by Arduino Mega relay drivers are used for signalling the direction of rotation of stepper motor. Figure below shows a basic circuit of relay driver.

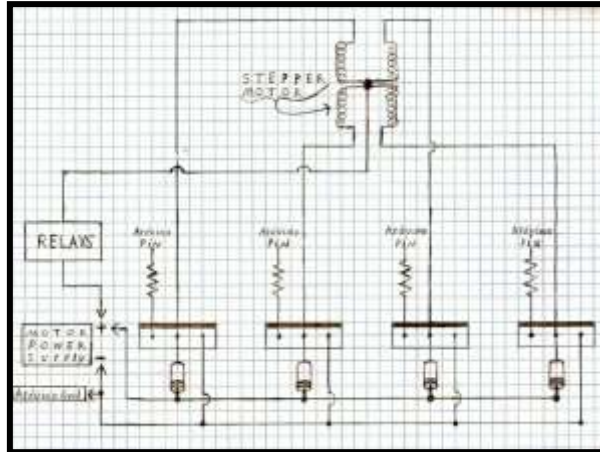

Figure 2.1: Relay circuit of one stepper motor [Google Image]

The Arduino uses DC power source to operate. To control the AC motor by Arduino an AC relay switch is used. HL-52S 2 channel relay is suitable to control AC motor of 240V. Figure below shows circuit diagram of AC motor control relay.

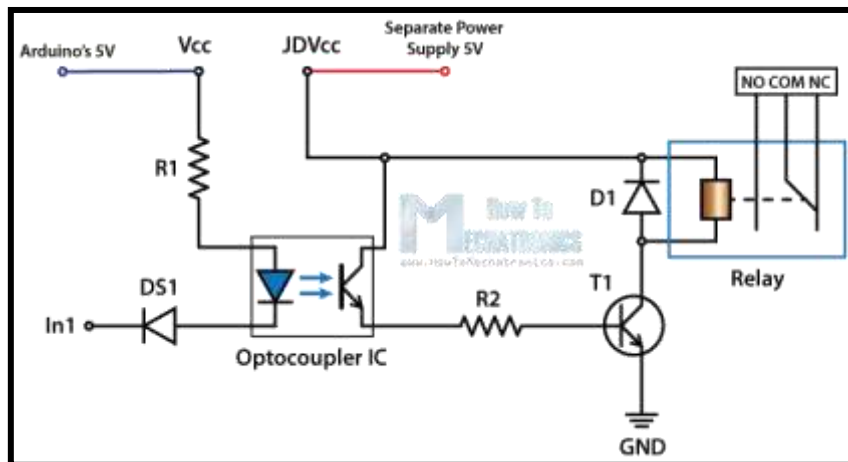

Figure 1.3: Circuit diagram of AC motor controller switch [Google Image]

III. PROPOSED METHODOLOGY

We are designing and fabricating Automatic Dustless Chalk Making Machine by using ECU. The basic structure hopper, electric motor, mold, stepper motor and ECU mounted on the frame. When the chalk mixture pours in the hopper, it is mixes in the hopper with help of blades for the definite time. The mixture is then poured into the mold and excess material is wiped out by slider which is connected to stepper motor. The heated water circulated around the mold and dries the mixture in the mold. The mold slides towards second station with the help of slider. At the second stage the ejection process takes places where ejector pushes the chinks out of mold with the help of stepper motor. All this processes are done automatically and controlled by ECU.

3.1 Steps for design and fabrication of machine

The Design and Fabrication of our Automatic Dustless Chalk making Machine is carried out in following steps –

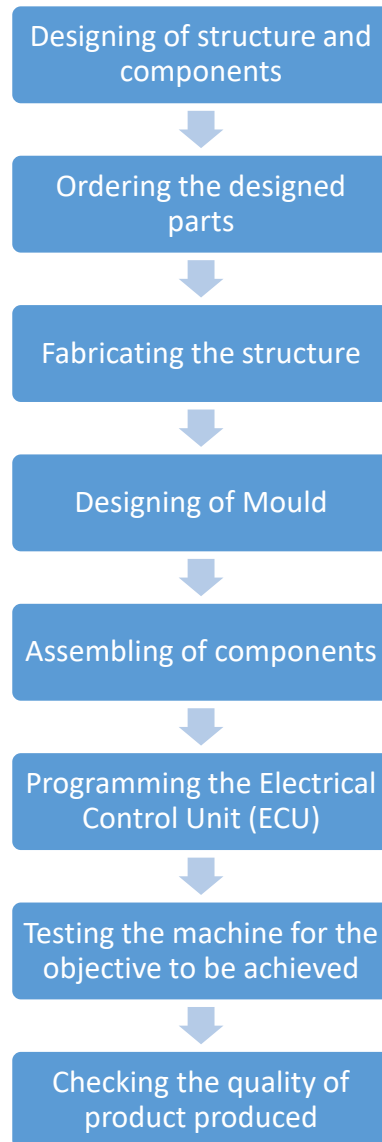

Figure 3.1: Steps followed in methodology

IV. CONCLUSION

We will be designing and fabricating the Automatic Dustless Chalk Making Machine. To do so we went through various research papers which helped us to understand the mechanisms and processes to fabricate the machine. As we get to know the main drawbacks of traditional machines in the market is high lead time and low productivity, we concentrate on reducing manpower, lead time and increasing the productivity. By using the stepper motors and electrical control units for automating the chalk making machine and also a heating system embedded in the project to reduce the drying time of the chinks. We have even designed mold and ejectors on the 3D model software.

V. REFERENCES

- [1] Abdurrahman, M.B. Obi, A.I. Baba M.T, "Design, construction and commissioning of a Chalk Extrusion machine", International Journal of Scientific & Technology Research, Vol. 2, 2013, pp. 302-304
- [2] Mrs. G. Udayshree, Mr. V. Ratnakiran, "Design and modelling of mechanisms used for chalk manufacturing in semi-automated chalk making machine", International Journal of Mechanical Engineering, Vol 3, 2015 pp. 22-25
- [3] I.G Davou Chomo, L.I. Pam, Z.S. Johnson, "Design, Construction and Testing of a Chalk Moulding Machine", International Journal of Academic Engineering Research, Vol 2, 2018 pp. 1-5
- [4] Rajendra S. Thakur, Jignesh J. Shukla, "Understanding the factors influencing quality of writing and wiping for chalk and board system", Current Science. Vol. 112, pp. 1727-1737
- [5] R. Hari Sudhan, M. Ganesh Kumar, "Arduino ATMEGA-328 Microcontroller", International Journal of Innovative Research in Electrical, Electronic and Control Engineering, Vol. 3, 2015 pp. 27-29
- [6] Swapnil Patil, Ramesh Patil, "Controlling stepper motor using Arduino UNO", International Research Journal of Engineering and Technology, Vol. 5, 2018 pp. 3540-3542
- [7] Joana Noble, Karl Walczak, "Rapid Tooling Injection Moulded Prototyping", Science Direct, Vol. 14, 2014 pp. 251-256
- [8] Ravi Waswani, Aakansha Pawar. "Induction motor fault detection, protection and speed control using Arduino", International Conference on Innovations in Information, Embedded and Communication Systems, 2015 pp. 1-5
- [9] Nathan David, Abafor Chima, "Design of Home Automation System using Arduino", International Journal of Scientific & Engineering Research, Vol 6, 2015 pp 795-801
- [10] R Krishan, "Selection criteria for Servo Motor Drives", IEEE Transactions on Industry Applications, Vol 23, 1978 pp 270-27